

13790510059

5

4

3

2

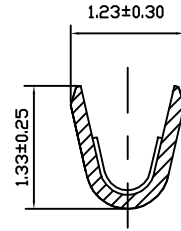
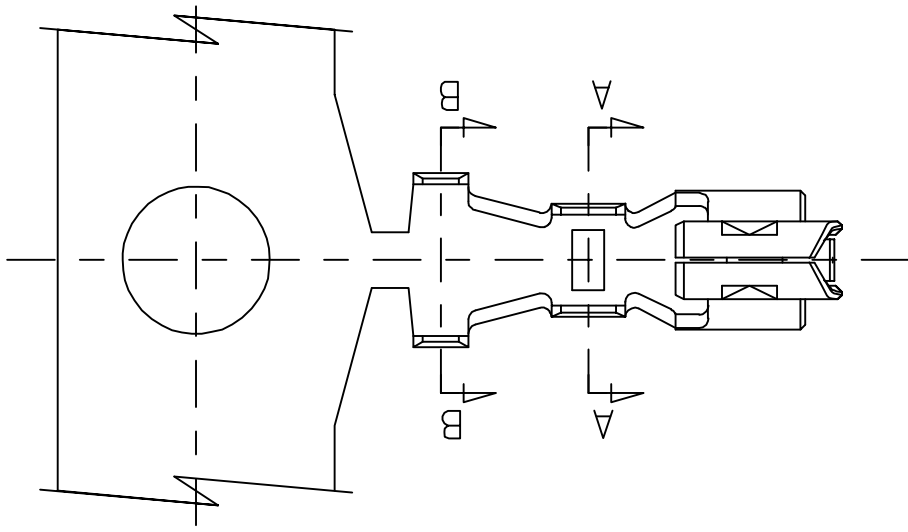

SECT.A-A

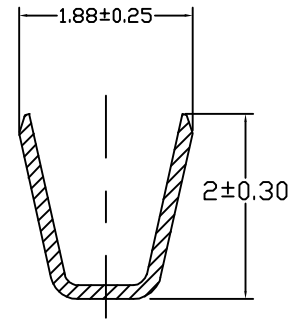
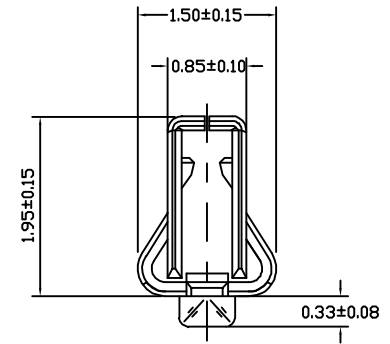

SECT.B-B

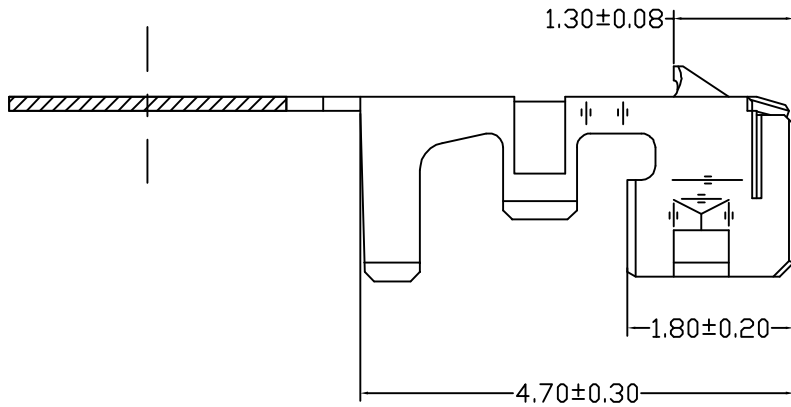

EST2014 T P X - 2 X - G

↑ 羿通代码+间距 ↑ T示意端子 ↑ X普通脚 ↑ H高脚 ↑ E增高脚 ↑ 0素材 ↑ X普通 ↑ X公端
 ↑ L长 ↑ G母端 ↑ C示意90° ↑ S示意180°

P磷铜 2镀锡先冲后镀
 B黄铜 3镀锡先镀后冲
 E合金铜 5G、15G示意镀金5U*或15U*
 1G示意镀金1U*

SPECIFICATIONS

- Voltage rating: 250V DC/AC (rms)
- Current rating: 2.0A
- Withstand voltage: 800V AC(rms)
- Working Temperature: -25°C +85°C
- Insulation resistance: ≥1000MΩ
- Contact resistance: ≤0.02Ω



东莞市羿通实业有限公司
DONGGUAN EASTOM ELECTRONIC Co., Ltd.

料号PART NO: EST2014TPX-2X-G

品名 TITLE: 50212-T

材料: C5191 单位: MM 包装规格: 10K/卷 比例: 1:1

日期版次 REVISION 日期 DATE 变更内容 DESCRIPTION 核 准 APPROVALBY 制图: 审核: 核准: 日期: 2022/6/20

一般公差
 GENERAL TOLERANCE
 X.X ±0.15
 X.XX ±0.05
 ANGLE ±1°

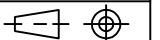

EST

6

5

4

3

2

1