

NOTES:

CURRENT RATING: 1A AC/DC
 VOLTAGE RATING: 100V AC/DC
 TEMPERATURE RANGE: -25°C~+85°C
 CONTACT RESISTANCE: 20mΩ MAX
 INSULATION RESISTANCE:1000MΩ MIN
 WITHSTANDING VOLTAGE:800V AC/MINUTE
 FLASH: 0.05MAX;WARPAGE: 0.08MAX

EST1001 W VS - 2*N_P X - X - 6S - NK-HF

W 示意针座
 W后无0默认材质为V0
 W后带2示意V2

VS 180° 直针, VS立式
 R 示意90° 弯针, RS卧式

2*N_P PIN数
 1单排
 2双排

X X本色
 B蓝色
 R红色
 L蓝色
 Y黄色
 G绿色

X普通
 B带扣
 U超薄
 PH组合排针
 FH组合排母

6S - NK-HF
 NK为NO MARK
 MK为有MARK
 XG中的X示意尼龙料,
 1为PPS, 2为PBT, 3为LCP, 4为ABS, 5为PA6T,
 6为PA66
 G示意PIN针镀金, S为PIN针镀锡

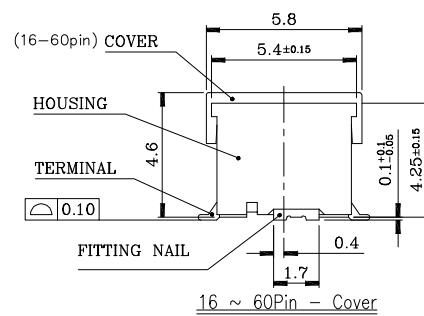
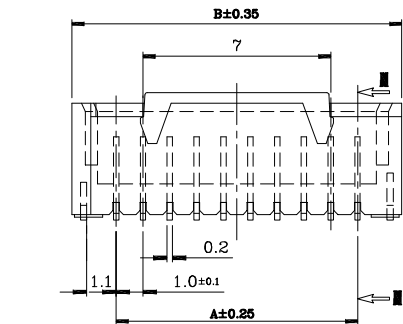
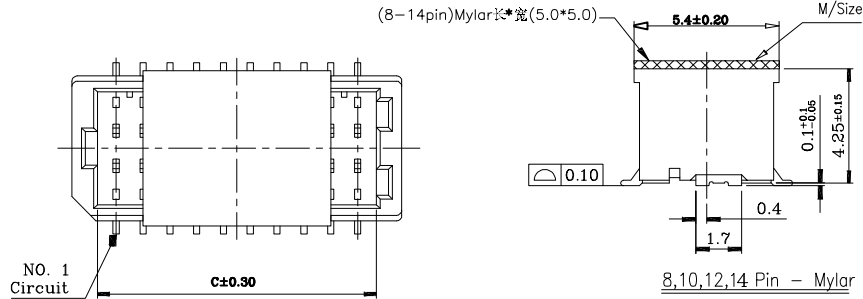
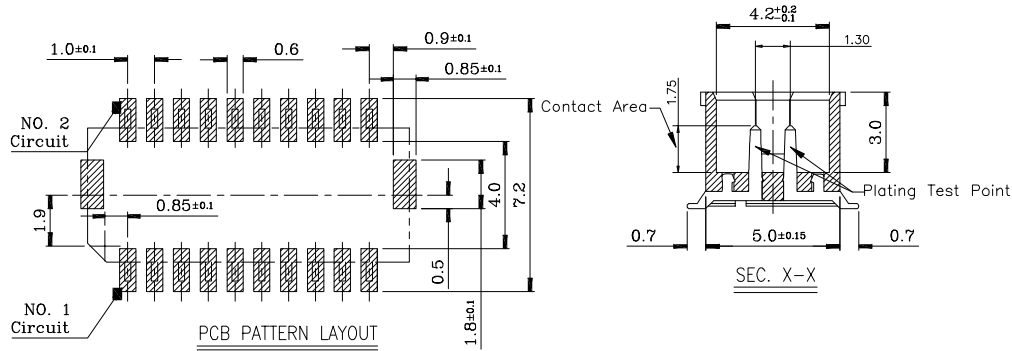

Circuit No.	Dimensions		
	A	B	C
08P	3.0	6.3	4.4
10P	4.0	7.3	5.4
12P	5.0	8.3	6.4
14P	6.0	9.3	7.4
16P	7.0	10.3	8.4
18P	8.0	11.3	9.4
20P	9.0	12.3	10.4
24P	11.0	14.3	12.4
28P	13.0	16.3	14.4
30P	14.0	17.3	15.4
34P	16.0	19.3	17.4
40P	19.0	22.3	20.4
50P	24.0	27.3	25.4
50P	29.0	32.3	30.4

Company Name: DONGGUAN EASTOM INDUSTRIAL CO., LTD
 Address: 1/2 WORKSHOP BUILDING NO. 53 LONGYAN NINTH ROAD, HUMEI TOWN
 DONGGUAN GUANGDONG CHINA
 Tell: 13790510059

3	FITTING NAIL	2	BRASS
2	TERMINAL	~	BRASS
1	HOUSING	1	THERMAL PLASTIC, UL94-V0
NO.	DESCRIPTION	Q'TY.	MATERIAL

日期版次 REVISION	日期 DATE	变更内容 DESCRIPTION	核 准 APPROVAL BY	料号PART NO: EST1001WVS-2*NPX-X	品名 TITLE: SH1.0立式双排	材料:	单位: MM	包装规格: 1K/包	比例: 1:1	一般公差 GENERAL TOLERANCE X, X ±0.30 X, XX ±0.25 X, XXX ±0.10 ANGLE ±1°
				制图: 胡宗显	审核: 李海平				日期: 2022/03/10	



东莞市羿通实业有限公司
 DONGGUAN EASTOM ELECTRONIC Co., Ltd.

