

a-a SECTION

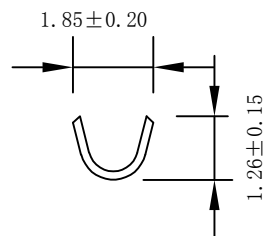

b-b SECTION

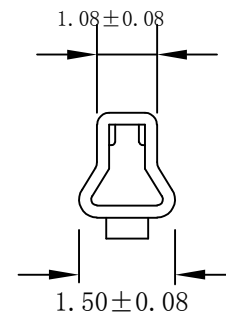
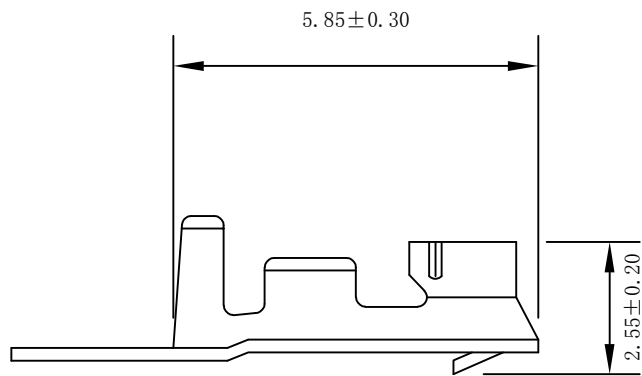

EST2508 T P X - 2 X - X

- 普通代码+间距
- T示端子
- P磷铜
- B黄铜
- E合金铜
- X普通脚
- H高脚
- E增高型脚
- 0素材
- 2镀锡先冲后镀
- 3镀锡先镀后冲
- 4镀全镍(镀后冲)
- 4.2镀全镍先冲后镀
- 5G、15G示意镀金5U°或15U°, 1G示意镀金1U°
- X普通
- L长
- S短
- U超薄
- X公端
- G母端
- C示意90°
- S示意180°

SPECIFICATIONS

- Applicable wire:AWG#22~#28
- Voltage rating: 250V DC/AC (rms)
- Current rating:2.5-1.0A
- Withstand voltage: 800V AC(rms)
- Working Temperature:-25℃+85℃
- Insulation resistance:≥1000MΩ
- Contact resistance:≤0.02Ω



东莞市羿通实业有限公司
DONGGUAN EASTOM ELECTRONIC Co., Ltd.

				料号PART NO: EST2508TPX-2X-G				一般公差 GENERAL TOLERANCE	
				品名 TITLE: EH2.5-T				X.X ±0.30	
				材料: C5191		单位: MM		X.XX ±0.20	
				制图: LI		审核: LI		X.XXX ±0.05	
				日期版次 REVISION		日期 DATE		ANGLE ±1°	
				变更内容 DESCRIPTION		核 准 APPROVALBY		比例: 1:1	
						包装规格:10K/卷		日期: 2022/7/2	
						核准: LI		EST	