

13790510059

5

4

3

2

1

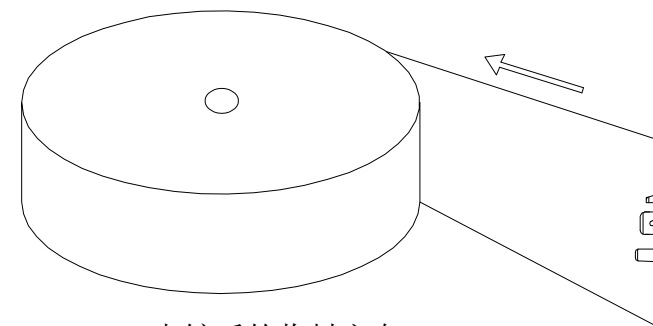
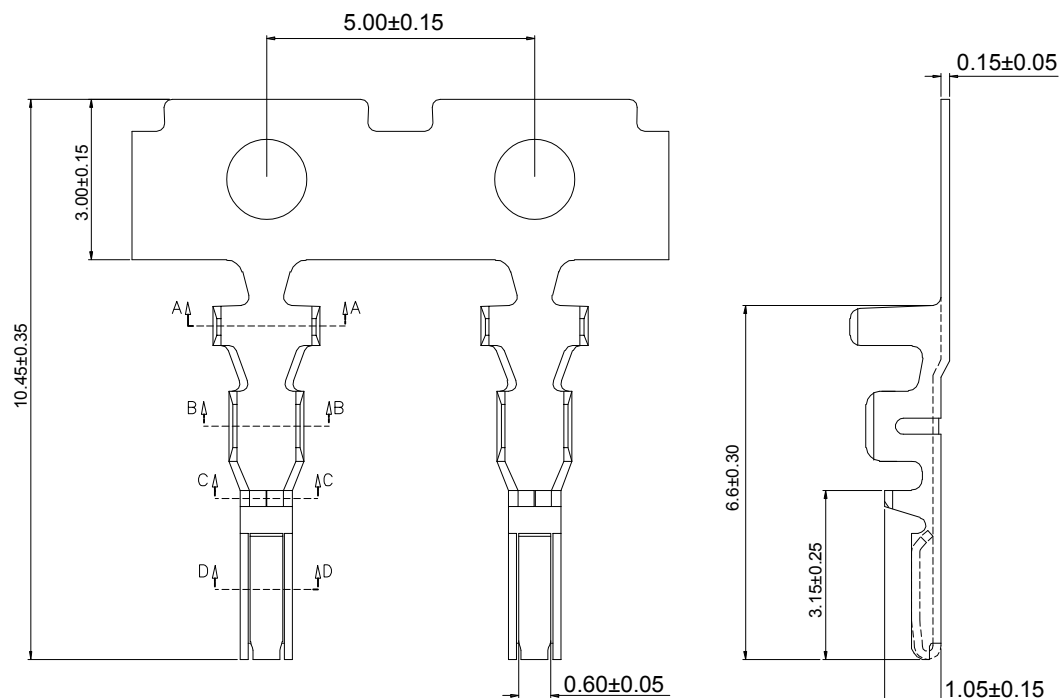

电镀后的收料方向
(开口向内)

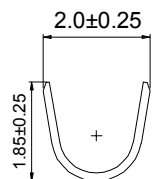

Specion A--A

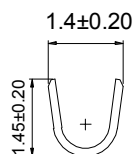

Specion B--B

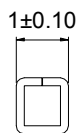

Specion C--C

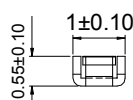

Specion D--D

SPECTION

- Current rating: 2A AC, DC (AWG #24)
- Voltage rating: 100V AC, DC
- Temperature range: -25°C to +85°C (including temperature rise in
- Contact resistance: Initial value/30mΩ max.After environmental testing /60mΩ max.
- Insulation resistance: 500M Ω min.
- Withstanding voltage: 500V AC/minute
- Applicable wire: Conductor size/AWG #28 to #24
- Insulation O. D. /0.8 to 1.2mm

EST1502 T P X - 2 X- G

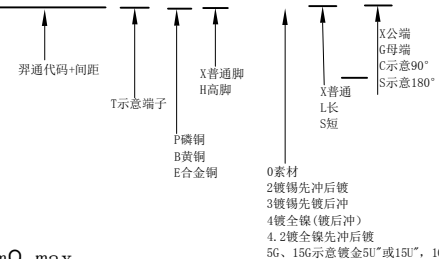

东莞市羿通实业有限公司
DONGGUAN EASTOM ELECTRONIC Co., Ltd.

料号PART NO: EST1502TPX-2X-G

品名 TITLE: ZP1502-T

材料: C5191

单位: MM

包装规格:

比例: 1:1

制图:

审核:

核准:

日期: 2021.12.08

一般公差
GENERAL TOLERANCE
X, X ±0.30
X, XX ±0.25
ANGLE ±1°

日期版次 REVISION	日期 DATE	变更内容 DESCRIPTION	核 准 APPROVALBY



XJ