

13790510059

5

4

3

2

1

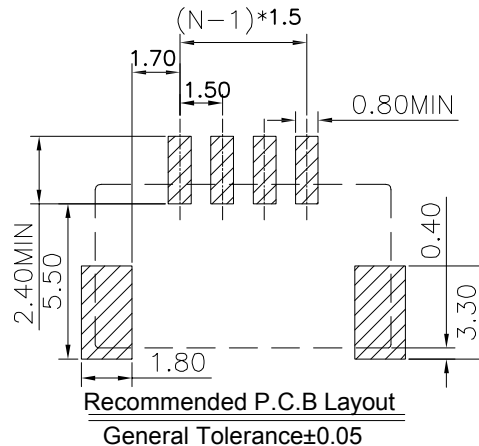
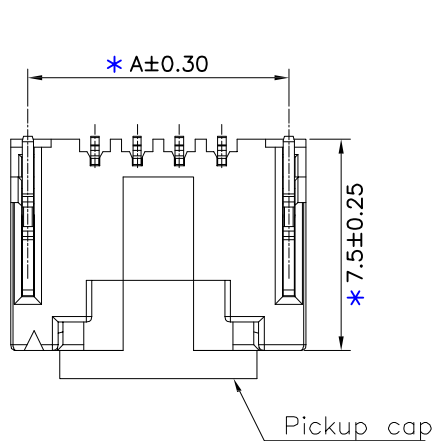

EST1505 W VS - 1*NP X - X X - X X - NK-HF

EST: 零件代码+料号
 W: 1单排 2双排
 VS: V示意180°直针, VS立式; R示意90°弯针, RS卧式
 NP: NP取
 X: X本色, B蓝色, R红色, L绿色, Y黄色, G绿色
 X: X普通, B带扣, L磁座, 附组合排针, 附组合排母, 磁号, P字母
 X: X磁座型, 2示意有磁, 3示意无磁
 X X: X为PIN针脚数
 NK: NK为PIN脚数
 HF: 磁无高, NP普通高磁
 NK: NK为MARK, 磁为有MARK
 1为PPS, 2为PBT, 3为LCP, 4为ABS, 5为PA6T, 6为PA66

W示意针座
 W后无0默认材质为V0
 W后带2示意V2

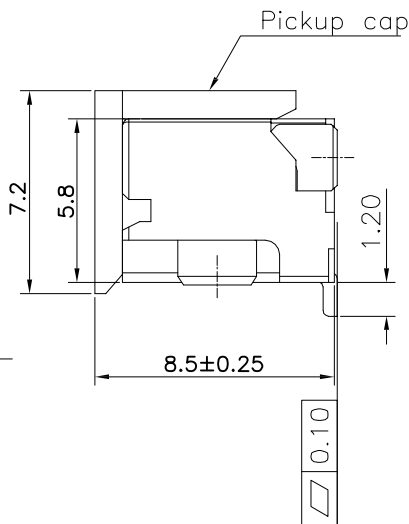
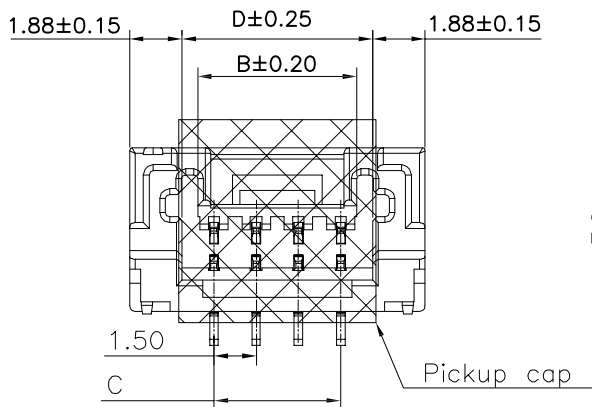

Poles	Dimensions (mm)			
	A±0.2	B±0.2	C±0.2	D±0.2
02	6.25	2.65	1.50	3.75
03	7.75	4.15	3.00	5.25
04	9.25	5.65	4.50	6.75
05	10.75	7.15	6.00	8.25
06	12.25	8.65	7.50	9.75
07	13.75	10.15	9.00	11.25
08	15.25	11.65	10.50	12.75
09	16.75	13.15	12.00	14.25
10	18.25	14.65	13.50	15.75
11	19.75	16.15	15.00	17.25
12	21.25	17.65	16.50	18.75
13	22.75	19.15	18.00	20.25
14	24.25	20.65	19.50	21.75
15	25.75	22.15	21.00	23.25
16	27.25	23.65	22.50	24.75

Specifications :

- Voltage rating: 125V AC / DC
- Current rating: 2A AC / DC
- Withstanding voltage: 800V AC/minute
- Temperature range: -40°C~+105°C
- Insulation resistance: ≥500MΩ
- Contact resistance: ≤20mΩ
- After environmental testing : ≤40mΩ
- Material(Pin) : Phosphor bronze

日期版次 REVISION	日期 DATE	变更内容 DESCRIPTION	核 准 APPROVALBY



东莞市羿通实业有限公司
DONGGUAN EASTOM ELECTRONIC Co., Ltd.

料号PART NO: EST1505WVS-1*NPX-B				一般公差 GENERAL TOLERANCE X.X ±0.25 X.XX ±0.20 ANGLE ±1°
品名 TITLE: 1505立贴				
材料:	单位: MM	包装规格:	比例: 1:1	
日期:	审核:	核准:	日期: 2021.10.25	

6

5

4

3

2

1

SL