

13790510059

5

4

3

2

1

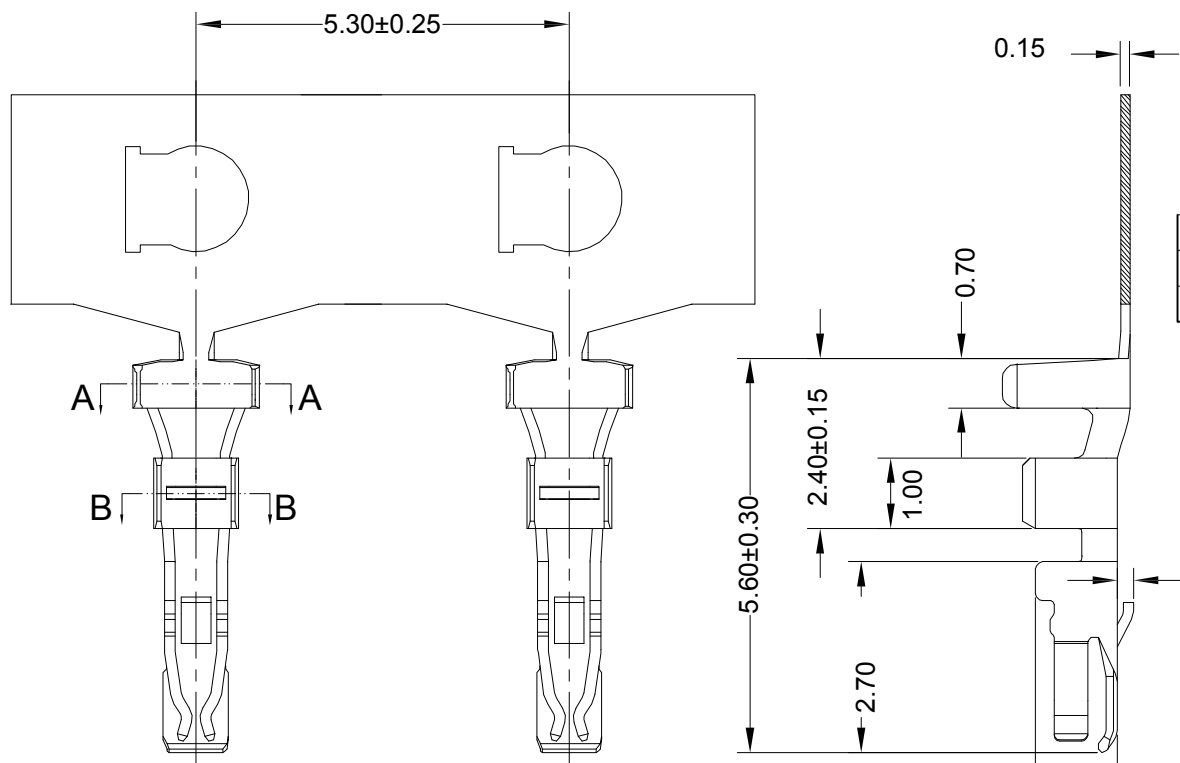

1507-T	Phosphor Bronze	AWG#24-28	1.10mm(Max)	Stamping Before Plating:30u" Ni MIN; Gold Flash	1507H
1507-T				Stamping Before Plating:30u" Ni MIN; 70u"Sn Min.	
PART NO	Material	Wire Range	Insulation	O.D.	Used In EST Housing

- Specifications :
- Voltage rating: 150V AC / DC
 - Current rating: 3A AC / DC
 - Withstanding voltage: 500V AC/minute
 - Temperature range: -25°C~+85°C
 - Insulation resistance: ≥1000MΩ
 - Contact resistance: ≤20mΩ
 - After environmental testing: ≤40mΩ

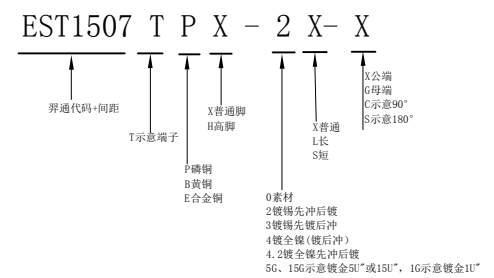
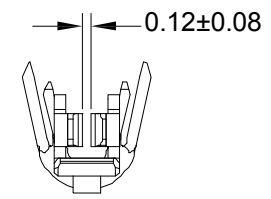
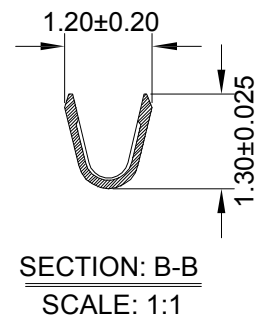
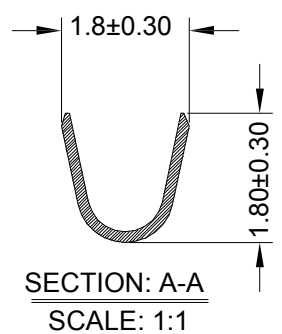

EST 东莞市羿通实业有限公司
DGEASTOM DONGGUAN EASTOM ELECTRONIC Co., Ltd.

料号PART NO: EST1507TPX-2X-G				一般公差 GENERAL TOLERANCE	
品名 TITLE: 1507-T				X.X ±0.30	
材料:		单位: MM	包装规格:	X.XX ±0.25	
日期版次 REVISION		日期 DATE	变更内容 DESCRIPTION	核 准 APPROVALBY	比例: 1:1
制图:		审核:	核准:	日期: 2021.12.08	ANGLE ±1°

6

5

4

3

2

1

SL